

## Injector - INJ 1010 - 2703007

Please be informed that the data shown in this PDF Document is generated from our Online Catalog. Please find the complete data in the user's documentation. Our General Terms of Use for Downloads are valid (<http://phoenixcontact.com/download>)



PoE injector, 60 W, two RJ45 jacks, 10/100/1000 Mbps, DIN rail mounting, IP20

### Product Description

The midspan injectors connect Ethernet devices without PoE (e.g., switches) to PoE-capable end devices (e.g., IP cameras). As power sourcing equipment (PSE), the injector supplies the required power to a powered device (PD) via the data cable. The injector and end device negotiate the electrical power requirements autonomously.

### Your advantages

- Extended supply voltage range of 18 V DC ... 57 V DC, redundant
- Safe shield connection to ground potential
- Mounting on a DIN rail
- 10/100/1000 Mbps



### Key Commercial Data

Packing unit	1 pc
GTIN	 4 055626 462950
GTIN	4055626462950
Weight per Piece (excluding packing)	340.000 g
Custom tariff number	85176200
Country of origin	Taiwan

### Technical data

#### Note

Utilization restriction	EMC: class A product, see manufacturer's declaration in the download area
-------------------------	---

### Dimensions

# Injector - INJ 1010 - 2703007

## Technical data

### Dimensions

Width	30.2 mm
Height	130 mm
Depth	120 mm

### Ambient conditions

Ambient temperature (operation)	0 °C ... 60 °C
Ambient temperature (storage/transport)	-40 °C ... 85 °C
Permissible humidity (operation)	10 % ... 95 % (non-condensing)
Altitude	≤ 5000 m (For restrictions, see the manufacturer's declaration for altitude operation)
	≤ 2000 m (With UL approval)
Degree of protection	IP20 (Non-certificated by UL)

### General

External cable diameter	5.5 mm ... 6.5 mm
Electromagnetic compatibility	Conformance with EMC Directive 2014/30/EU
Mounting position	vertical
Mounting type	DIN rail mounting
Net weight	394.5 g
Housing material	Plastic
Color	gray
MTTF	133.8 Years (MIL-HDBK-217F standard, temperature 25°C, operating cycle 100%)

### Power supply

Nominal supply voltage	24 V DC
	48 V DC
Supply voltage range	18 V DC ... 57 V DC (Ordinary locations)
	24 V DC ... 48 V DC (Hazardous locations)
Max. current consumption	4.2 A
	2.73 A (24 V DC)
	1.34 A (48 V DC)
Power consumption	≤ 75 W
Protective circuit	Reverse polarity protection
Conductor cross section flexible, with ferrule without plastic sleeve	0.25 mm <sup>2</sup> ... 2.5 mm <sup>2</sup>
Conductor cross section, flexible, with ferrule, with plastic sleeve	0.25 mm <sup>2</sup> ... 2.5 mm <sup>2</sup>
Conductor cross section flexible max.	2.50 mm <sup>2</sup>
Conductor cross section flexible min.	0.20 mm <sup>2</sup>
Conductor cross section solid max.	2.50 mm <sup>2</sup>
Conductor cross section solid min.	0.20 mm <sup>2</sup>

# Injector - INJ 1010 - 2703007

## Technical data

### Power supply

Conductor cross section AWG max.	12
Conductor cross section AWG min.	20

### Interfaces

Interface 1	Power over Ethernet
No. of ports	1
Connection method	RJ45 jack
Transmission length	100 m (including patch cables)
Pin assignment	1:1
Basic functions	PSE/Midsparn, compliant with IEEE 802.3af, at
Serial transmission speed	10/100/1000 Mbps
Output nominal voltage	54 V DC (PoE)
Output power	60 W
Interface 2	Ethernet
Connection method	RJ45 CAT5e

### Conformance/approvals

Designation	CE
Identification	CE-compliant
Designation	UL, USA/Canada
Identification	Class I, Div. 2, Groups A, B, C, D T4
Designation	Corrosive gas test
Identification	ISA-S71.04-1985 G3 Harsh Group A

### Standards and Regulations

Electromagnetic compatibility	Conformance with EMC Directive 2014/30/EU
Type of test	Vibration resistance in acc. with EN 60068-2-6/IEC 60068-2-6
Test result	10 Hz ... 57 Hz, amplitude $\pm 3.5$ mm, 57 Hz ... 150 Hz, 5g
Type of test	Shock in acc. with EN 60068-2-27/IEC 60068-2-27
Test result	30g for 11 ms, three shocks in each spatial direction
Type of test	Continuous shock according to EN 60068-2-27/IEC 60068-2-27
Test result	10g for 16 ms, 1000 shocks in each spatial direction
Standards/regulations	EN 61000-4-2
Contact discharge	$\pm 6$ kV (Test Level 3)
Indirect discharge	$\pm 6$ kV
Standards/regulations	EN 61000-4-3
Frequency range	80 MHz ... 3 GHz (Test Level 3)
Standards/regulations	EN 61000-4-4
Comments	Criterion B

# Injector - INJ 1010 - 2703007

## Technical data

### Standards and Regulations

Standards/regulations	EN 61000-4-5
Signal	± 1 kV (Data line, asymmetrical)
	± 2 kV (I/O cable on field side only, asymmetric)
Standards/regulations	EN 61000-6-4
	EN 61000-4-6
Frequency range	0.15 MHz ... 80 MHz

### Environmental Product Compliance

China RoHS	Environmentally Friendly Use Period = 10;
	For details about hazardous substances go to tab "Downloads", Category "Manufacturer's declaration"

## Drawings

Dimensional drawing

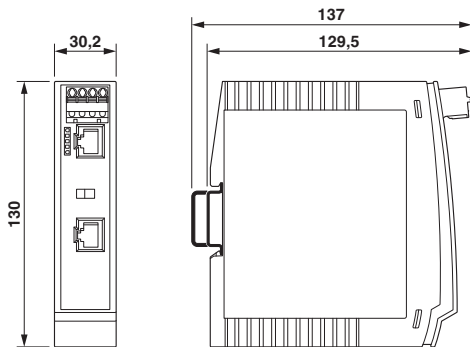

Schematic diagram

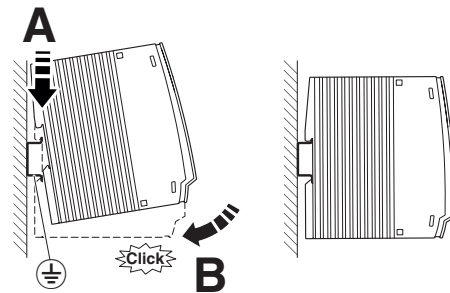

Mounting

# Injector - INJ 1010 - 2703007

Schematic diagram

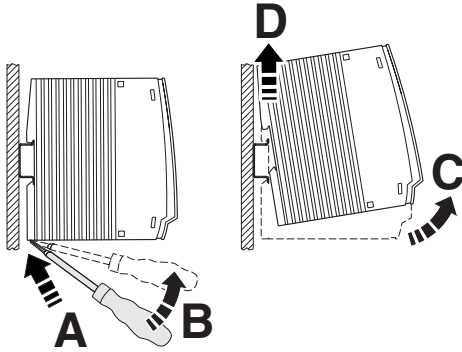

Removal

Schematic diagram

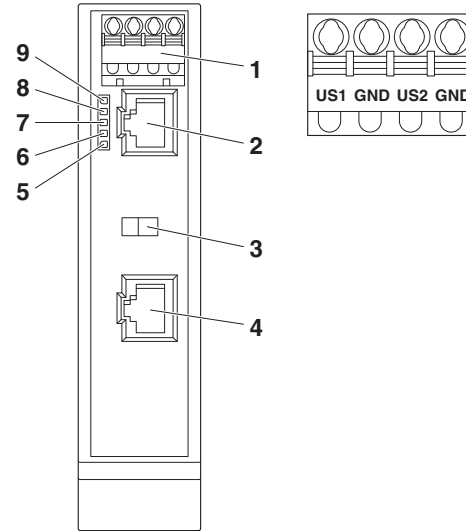

Front view

## Classifications

eCl@ss

eCl@ss 10.0.1	19170112
eCl@ss 11.0	19170112
eCl@ss 6.0	19170100
eCl@ss 7.0	19170112
eCl@ss 9.0	19170112

ETIM

ETIM 6.0	EC002599
ETIM 7.0	EC002599

## Approvals

Approvals

Approvals

UL Listed / cUL Listed / EAC / cULus Listed

# Injector - INJ 1010 - 2703007

## Approvals

Ex Approvals

UL Listed / cUL Listed / cULus Listed

### Approval details

UL Listed		<a href="http://database.ul.com/cgi-bin/XYV/template/LISEXT/1FRAME/index.htm">http://database.ul.com/cgi-bin/XYV/template/LISEXT/1FRAME/index.htm</a>	FILE E 238705
-----------	--	---	---------------

cUL Listed		<a href="http://database.ul.com/cgi-bin/XYV/template/LISEXT/1FRAME/index.htm">http://database.ul.com/cgi-bin/XYV/template/LISEXT/1FRAME/index.htm</a>	FILE E 238705
------------	--	---	---------------

EAC			RU *- DE.A*30.B.03171
-----	--	--	--------------------------

cULus Listed			
--------------	--	--	--

## Accessories

### Accessories

#### Data cable by the meter

Network cable - FL CAT5 HEAVY - 2744814



CAT5-SF/UTP cable (J-02YS(ST)C HP 2 x 2 x 24 AWG), heavy-duty installation cable, 2 x 2 x 0.22 mm<sup>2</sup>, solid conductor, shielded, outer sheath: 7.8 mm diameter, inner sheath: 5.75 mm ± 0.15 mm diameter

Installation cable - FL CAT5 FLEX - 2744830



By the meter, Installation cable, Ethernet CAT5 (100 Mbps), shielded, PUR halogen-free, water blue RAL 5021, 4-wire (2x2xAWG26/7; SF/UTP), color single wire: white/orange-orange, white/green-green, cable length: Free entry (1.0 ... 1000.0 m)

## Injector - INJ 1010 - 2703007

### Accessories

---

#### Network cable - VS-OE-OE-94F/... - 1417359



Network cable, Ethernet CAT6<sub>A</sub> (10 Gbps), 8-position, PUR halogen-free, water blue RAL 5021, shielded, free cable end, on free cable end, cable length: Free entry (0.5 ... 400 m)

---

#### Data cable preassembled

##### Network cable - FL CAT5 HEAVY CONF/ - 2744827



CAT5-SF/UTP cable (J-02YS(ST)C HP 2 x 2 x 24 AWG), heavy-duty installation cable, 2 x 2 x 0.22 mm<sup>2</sup>, solid conductor, shielded, outer sheath: 7.8 mm diameter, inner sheath: 5.75 mm ± 0.15 mm diameter, preassembled on both sides with RJ45 plug, crossover or line

---

##### Network cable - FL CAT5 FLEX CONF/ - 2744843



CAT5-SF/UTP cable (J-LI02YS(ST)C H 2 x 2 x 26 AWG), light-duty, flexible installation cable 2 x 2 x 0.14 mm<sup>2</sup>, stranded, shielded, outer sheath: 5.75 mm ± 0.15 mm diameter, preassembled on both sides with RJ45 plug, crossover or line assignment

---

#### Data plug

##### Assembly tool - FL CRIMPTOOL - 2744869



Crimping pliers, for assembling the RJ45 plugs FL PLUG RJ45..., for assembly on site

---

## Injector - INJ 1010 - 2703007

### Accessories

RJ45 connector - VS-08-RJ45-5-Q/IP20 - 1656725



RJ45 connector, degree of protection: IP20, number of positions: 8, 1 Gbps, CAT5 (IEC 11801:2002), material: PA, connection method: IDC fast connection, connection cross section: AWG 26- 23, cable outlet: straight, color: traffic grey A RAL 7042, Ethernet

RJ45 connector - VS-08-RJ45-5-Q/IP20 BK - 1658008



RJ45 connector, degree of protection: IP20, number of positions: 8, 1 Gbps, CAT5 (IEC 11801:2002), material: PA, connection method: IDC fast connection, connection cross section: AWG 26- 23, cable outlet: straight, color: black, Ethernet

### Electronics pliers

Diagonal cutter - MICROFOX-SP - 1212488



Electronic diagonal cutter, tapered head, angled (21°), without chamfer, with opening spring

### Network isolator

Network isolator - FL ISOLATOR 100-RJ/SC - 2313928



Passive network isolator for electrical isolation in Ethernet networks. This protects Ethernet devices from potential differences of up to 4 kV. Can be used for transmission speeds of up to 100 Mbps. Connection using RJ45 and COMBICON plug-in screw terminal block.

Network isolator - FL ISOLATOR 100-RJ/RJ - 2313931



Passive network isolator for electrical isolation in Ethernet networks. This protects Ethernet devices from potential differences of up to 4 kV. Can be used for transmission speeds of up to 100 Mbps. Possible to connect two RJ45 plugs.

## Injector - INJ 1010 - 2703007

### Accessories

---

#### Network isolator - FL ISOLATOR 1000-RJ/RJ - 2313915



Passive network isolator for electrical isolation in Ethernet networks. This protects Ethernet devices from potential differences of up to 4 kV. Can be used for transmission speeds of up to 1 Gbps. Possible to connect two RJ45 plugs.

---

#### Network isolator - FL ISOLATOR 100-M12 - 2902985



Passive network isolator for electrical isolation in Ethernet networks. For the protection of Ethernet devices against potential differences of up to 4 kV. Can be used for transmission speeds of up to 100 Mbps. Ethernet connection via two M12 sockets (D-coded).

---

#### Patch cable

##### Patch cable - FL CAT5 PATCH 0,3 - 2832250



Patch cable, CAT5, assembled, 0.3 m

---

##### Patch cable - FL CAT5 PATCH 0,5 - 2832263



Patch cable, CAT5, assembled, 0.5 m

---

##### Patch cable - FL CAT5 PATCH 1,0 - 2832276



Patch cable, CAT5, assembled, 1 m

---

## Injector - INJ 1010 - 2703007

### Accessories

Patch cable - FL CAT5 PATCH 1,5 - 2832221



Patch cable, CAT5, assembled, 1.5 m

---

Patch cable - FL CAT5 PATCH 2,0 - 2832289



Patch cable, CAT5, assembled, 2 m

---

Patch cable - FL CAT5 PATCH 3,0 - 2832292



Patch cable, CAT5, assembled, 3 m

---

Patch cable - FL CAT6 PATCH 0,3 - 2891181



Patch cable, CAT6, pre-assembled, 0.3 m

---

Patch cable - FL CAT6 PATCH 0,5 - 2891288



Patch cable, CAT6, pre-assembled, 0.5 m

---

## Injector - INJ 1010 - 2703007

### Accessories

Patch cable - FL CAT6 PATCH 1,0 - 2891385



Patch cable, CAT6, pre-assembled, 1.0 m

---

Patch cable - FL CAT6 PATCH 1,5 - 2891482



Patch cable, CAT6, pre-assembled, 1.5 m

---

Patch cable - FL CAT6 PATCH 2,0 - 2891589



Patch cable, CAT6, pre-assembled, 2.0 m

---

Patch cable - FL CAT6 PATCH 3,0 - 2891686



Patch cable, CAT6, pre-assembled, 3.0 m

---

Patch cable - FL CAT6 PATCH 5,0 - 2891783



Patch cable, CAT6, pre-assembled, 5.0 m

---

## Injector - INJ 1010 - 2703007

### Accessories

Patch cable - FL CAT6 PATCH 7,5 - 2891880



Patch cable, CAT6, pre-assembled, 7.5 m

---

Patch cable - FL CAT6 PATCH 10 - 2891877



Patch cable, CAT6, pre-assembled, 10 m

---

Patch cable - FL CAT6 PATCH 12,5 - 2891369



Patch cable, CAT6, pre-assembled, 12.5 m

---

Patch cable - FL CAT6 PATCH 15,0 - 2891372



Patch cable, CAT6, pre-assembled, 15.0 m

---

Patch cable - FL CAT6 PATCH 20,0 - 2891576



Patch cable, CAT6, pre-assembled, 20.0 m

---

### Screwdriver tools

## Injector - INJ 1010 - 2703007

### Accessories

Screwdriver - SZF 0-0,4X2,5 - 1204504



Actuation tool, for ST terminal blocks, also suitable for use as a bladed screwdriver, size: 0.4 x 2.5 x 75 mm, 2-component grip, with non-slip grip

---

Stripping tool - VS-CABLE-STRIP-VARIO - 1657407



Stripping tool, for the multi-level stripping of shielded cables